

SERFILCO®

SERIES 'S' SELF-PRIMING CENTRIFUGAL PUMPS

BULLETIN
P-630B
SEPT. 2004

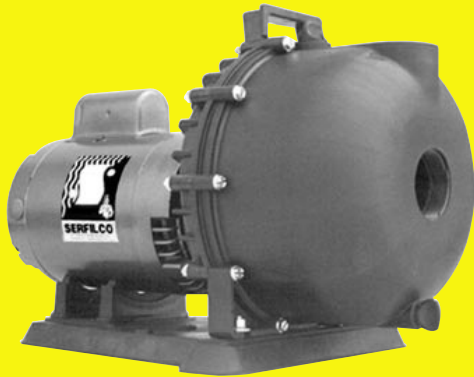

**CLOSE-COUPLED
ELECTRIC**

*Also available as long coupled, pedestal mounted pump.
(Consult Sales Department.)*

SELF-PRIMING CENTRIFUGAL PUMPS FOR TRANSFER AND RECIRCULATION OF:

**CHEMICAL SOLUTIONS
WASTE TREATMENT
ACIDS / INDUSTRIAL LIQUIDS**

- **Flows to 270 U.S. GPM or 120 ft. TDH @ 60 Hz**
(To 845 LPM or 25.0m TDH @ 50 Hz)
- **Choice of materials -**
glass reinforced polyester, polypropylene or Ryton® with 316 SS internal hardware
(See a chemical resistance chart)
- **Non-metallic solution contact models available**
- **Will reprime to 25 ft. (7.6m) vertical***
- **Close-coupled**
 - electric motor driven
 - gasoline engine driven
 - hydraulic drive
 - pneumatic drive
- **Built-in check valve**
- **BSP threads available on polyester models**

The Series 'S' Self-Priming Centrifugal Pump is a chemically resistant pump for general service on water, salt water, mild acids and bases. It is offered in a choice of glass reinforced polyester, polypropylene or Ryton construction to provide a maximum range of chemical resistance. It is available with a choice of elastomers and 316 stainless steel internal hardware or with completely non-metallic solution contact. The pump comes standard with 304 stainless external hardware.

All pumps include a built-in check valve and feature a self-cleaning double volute which allows the Series 'S' pump to self prime and lift to 25 ft.

The self priming capability and chemical resistance make this an ideal chemical transfer, waste treatment, and emergency / backup pump.

* Based on water-like liquids at 70°F and at 3450 RPM after initial priming of pump housing.



WASTE TREATMENT



SOLUTION TRANSFER

SERIES 'S' PUMPS Specifications

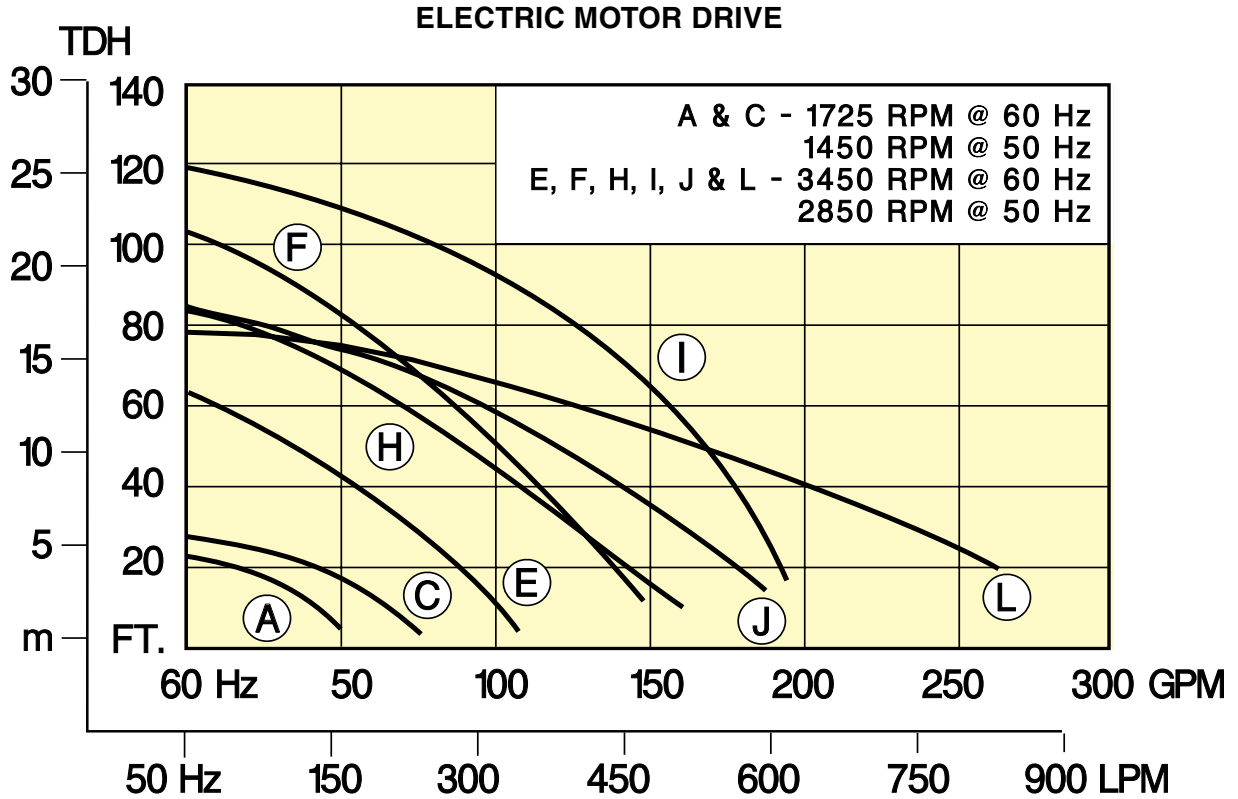

DIMENSIONS

**1½" & 2" Pumps
to 3.0 HP
(3 phase)**

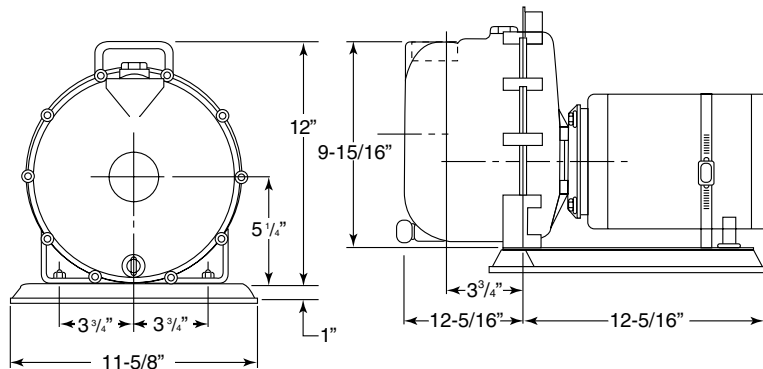

**2" & 3" Pumps
5.0 HP
(3 phase)**

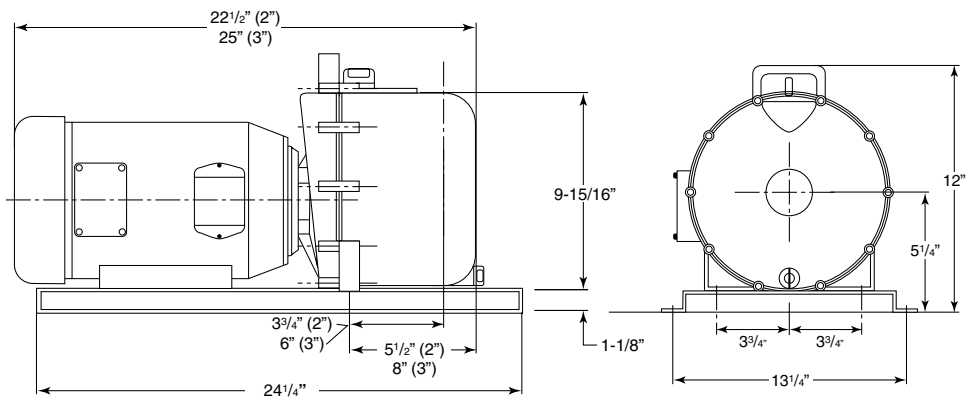

SERIES 'S' PUMPS Ordering information

TO ORDER - use Price Code Number

TABLE I

Pump molded of glass reinforced polyester with 316 stainless steel internal fasteners, 304 SS external fasteners, EPDM "O"-rings and gasket, check valve, polypropylene baseplate, close coupled electric motor.

FLOW CURVE LETTER	PORT SIZE	MAX. FLOW RATE		MAX. TDH		MAX. HP REQ'D		MODEL NUMBER	PRICE CODE NUMBER	ELECTRIC MOTOR 60 Hz		
		IN.	GPM @ 60 Hz	LPM @ 50 Hz	FT. @ 60 Hz	m @ 50 Hz	60 Hz /RPM			50 Hz /RPM	ADD TO MODEL & PRICE CODE NO . . .	
											115/230V/1/60	230/460V/3/60
		TEFC		TEFC								
A	1½	50	157	22	4.4	0.5/1750	0.3/1450	SE1½AL-	64-11A4-	G.5C	H.5C	
C	1½	70	219	27	5.6	1.0/1750	0.6/1450	SE1½CL-	64-11C4-	G1.0C	H1.0C	
E	2	110	344	62	13.0	1.4/3450	0.8/2850	SE2EL-	64-12E4-	C2.0C	D2.0C	
F	2	150	471	105	21.9	3.0/3450	1.7/2850	SE2FL-	64-12F4-	--	D5.0C	
H	2	155	485	82	17.1	2.6/3450	1.5/2850	SE2HL-	64-12H4-	--	D3.0C	
I	2	195	610	120	25.0	5.0/3450	2.8/2850	SE2IL-	64-12I4-	--	D5.0C	
J	2	185	579	83	17.3	4.0/3450	2.3/2850	SE2JL-	64-12J4-	--	D5.0C	
L	3	270	845	79	16.5	5.0/3450	2.8/2850	SE3LL-	64-13L4-	--	D5.0C	

TABLE II

To determine pump-motor for a selected GPM and/or TDH, first select the appropriate impeller from curve on the previous page. Use Table I to identify the part size for a given flow

curve. Multiply HP req'd shown in Table I by specific gravity to determine motor size. Select pump materials. Then construct Model and Price Code Numbers.

EXAMPLE:	PUMP	+	PORT	+	IMPELLER	+	SEAL	+	MOTOR	
MODEL	SE	+	2	+	E	+	L	+	-D2.0C	=SE2EL-D2.0C
PRICE CODE NO.	64-1	+	2	+	E	+	4	+	-D2.0C	=64-12E4-D2.0C

PUMP

PUMP	PRICE CODE NUMBER
SE (polyester)	64-1
SP (polypropylene) ²	64-2
SY (Ryton)	64-3

PORT + IMPELLER

PORT SIZE - NPT'		IMPELLER
MODEL	PRICE CODE NO.	MODEL & PRICE CODE NO.
1½	1	A,C
2	2	A,C,E,F,H,I,J
3	3	L

SEAL, ELASTOMERS & INTERNAL FASTENERS

DESCRIPTION	MODEL	PRICE CODE NO.
Viton w/316 stn. steel fasteners	V	1
Buna-N w/316 stn. steel fasteners	B	2
EPDM w/316 stn. steel fasteners	L	4
Non-metallic solution contact, EPDM	LN	88
Non-metallic solution contact, EPDM	VN	99

ELECTRIC MOTORS 60 Hz³

HP	RPM	ADD TO MODEL & PRICE CODE NO . . .	
		115/230V/1/60	230/460V/3/60
		TEFC	TEFC
.5	1750	G.5C	H.5C
.75	1750	G.75C	H.75C
1.0	1750	G1.0C	H1.0C
1.5	1750	G1.5C	H1.5C
2.0	3450	C2.0	D2.0C
3.0	3450	--	D3.0C
5.0	3450	--	D5.0C

- For BSP threads, add **B** in 4th digit of Model No. and change Price Code No. from **1** to **4**, **2** to **5**, **3** to **6**. Note: Impeller designation now becomes the 5th digit of model number only for BSP pumps.
- Polypropylene pump includes Ryton volute.
- For 50 Hz operation consult Sales Department.

SERIES "S" PUMPS - Hydraulic, Pneumatic or Engine Drive

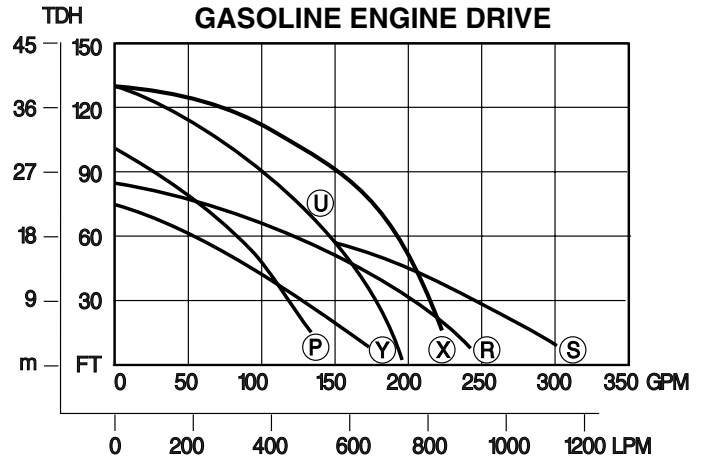
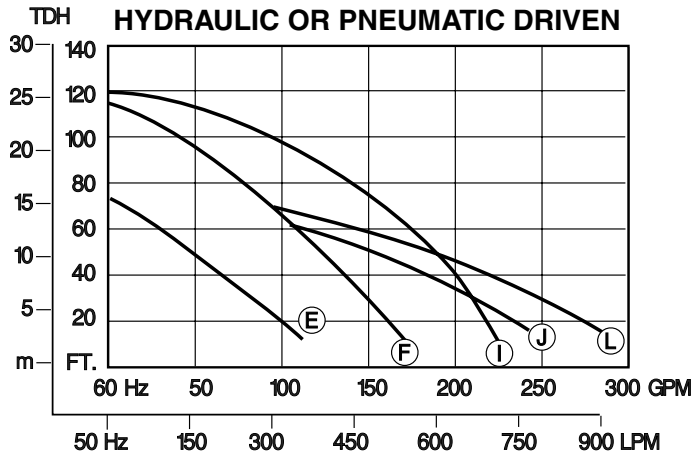

PUMP with GASOLINE ENGINE DRIVE, 3.5 to 8 HP

Molded of glass reinforced polyester with carrying handle, 316 stainless steel internal fasteners and 304 SS external fasteners. EPDM "O"-rings and gasket, check valve. Engine shaft shielded with heat shrink polyethylene tubing. Consult Application Engineering Department for diesel engine drive.

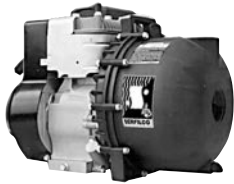

GASOLINE ENGINE DRIVE

FLOW CURVE LETTER	PORT SIZE	MAX. FLOW RATE		MAX. TDH		SHIPPING WEIGHT		MODEL NUMBER	PRICE CODE NO.	GASOLINE ENGINE			
										ADD TO MODEL &		PRICE CODE NO. . . .	
										STANDARD	HEAVY DUTY		
Y	1 1/2	150	567	76	23	40	19	SE1 1/2 YL -	64-11Y4-	-E3CP	-E3ACP		
P	2	170	643	100	30	40	19	SE2PL -	64-12P4				
R	2	220	832	83	25	46	23	SE2RL -	64-12R4-				
U	2	180	681	130	40	46	23	SE2UL -	64-12U4-	-E5CP	-E5ACP		
S	3	280	1060	83	25	50	24	SE3SL -	64-13S4-				
X	3	280	1060	126	38	70	32	SE3XL -	64-13X4-	--	-E8CP		



HYDRAULIC

PUMP with HYDRAULIC or PNEUMATIC DRIVE

Pump molded of glass reinforced polyester with 316 stainless steel internal fasteners, 304 SS external fasteners, EPDM "O"-rings, gasket and check valve. Pneumatic driven includes a steel baseplate. Motor shaft is a 316 stainless steel stubshaft.



PNEUMATIC

FLOW CURVE LETTER	PORT SIZE	HYDRAULIC @ 3450 RPM					PNEUMATIC @ 2900 RPM					SHIP. WT LBS.		MODEL NUMBER	PRICE CODE NUMBER	ADD TO	
		MAX. FLOW RATE		MAX. TDH	MAX. HP	MAX. FLOW RATE		MAX. TDH	MAX. HP	HY	PN					MODEL &	PRICE CODE NUMBER
		IN.	GPM			LPM	FT.										
E	2	110	416	71	22	1.7	90	340	49	15	1.0	18	44	SE2EL-	64-12E4-		
F	2	160	605	115	35	3.6	133	503	80	24	2.1	18	44	SE2FL-	64-12F4-		
I	2	230	870	120	37	6.6	190	719	83	25	3.8	18	44	SE2IL-	64-12I4-	-HYC	-PNC
J	2	240	908	75	23	5.0	200	757	52	16	2.9	18	44	SE2JL	64-12J4-		
L	3	280	1060	75	23	5.0	242	915	52	16	2.9	21	47	SE3LL-	64-13L4		

F.O.B. Northbrook, Illinois

Specifications subject to change without notice.

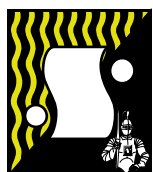

SERFILCO, LTD.

2900 MacArthur Blvd. 847-509-2900
 Northbrook, IL 60062-2005 U.S.A. 800-323-5431
 e-mail: sales@serfilco.com FAX: 847-559-1995
 www.serfilco.com

DISTRIBUTED BY