

SERIES 'EO' MOLDED VERTICAL PUMPS

Efficient and dependable performance for:

**ACIDS / CAUSTICS / CLEANERS
CHEMICALS / PCB / PLATING
WATER / WASTE WATER**

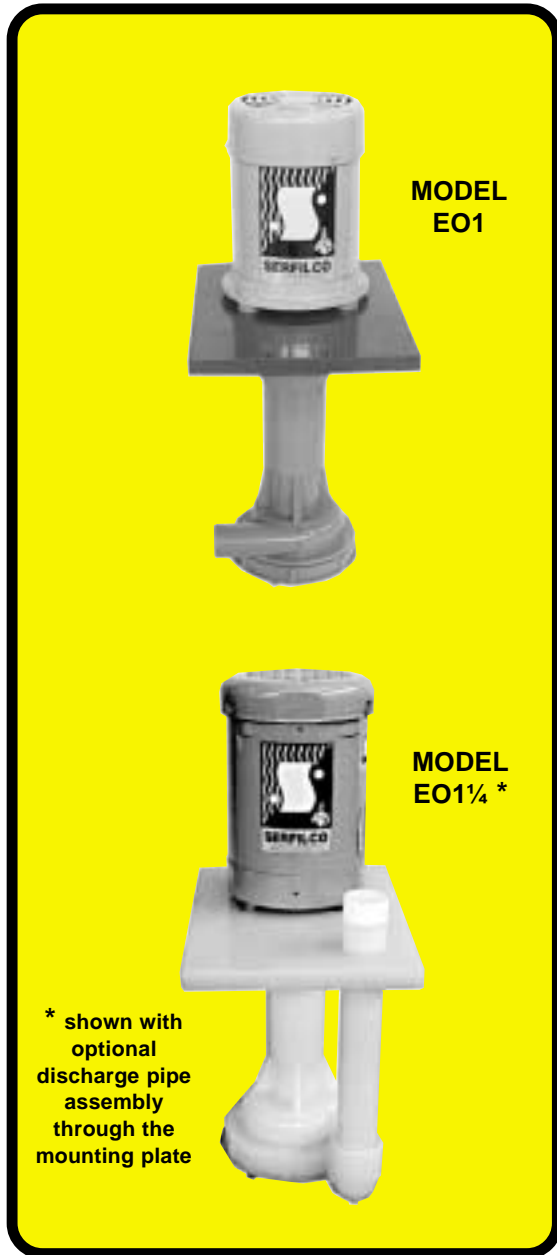

- **Flows to 92 U.S. GPM or 68 ft. TDH @ 60 Hz**
(288 LPM or 14.4m @ 50 Hz)
- **Non-metallic solution contact**
PPP high temperature polypropylene, CPVC or 100% PVDF
Viton® or EPDM elastomers
(See a chemical resistance chart)
- **Runs dry** — seal-less, no bearings
- **Chemical duty motor (1/3 - 1.5 HP)**
Sealed, oversized bearings, cast iron end bells.
Corrosion resistant two-part epoxy enamel finish,
stainless steel nameplate.
1.15 service factor at 50 and 60 Hz.
- **Centrifugal** — quiet, vibration-free
- **In- or out-of-tank installation**
- **Will replace most OEM pumps**

The Series 'EO' pump benefits from proven design features gained through over 30 years of experience in developing chemically resistant vertical pumps.

The unique design of this pump includes a fully sleeved stainless steel shaft threaded into a chemical duty motor. This eliminates weak shaft connections, pump bearings, spindles, bushings and liners, resulting in a chemical duty pump which can run dry indefinitely, providing years of trouble-free service.

Standard models include a heavy duty machined mounting plate with Teflon® vapor seal and column labyrinth seal to protect the motor. The compound impeller prevents liquid from rising in the column, even at maximum TDH, while the semi-enclosed bottom impeller provides efficient flow performance at low horsepower.

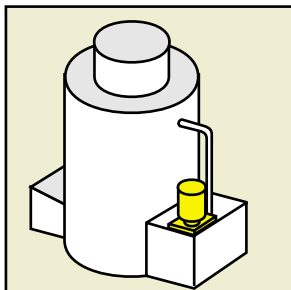

FUME SCRUBBING

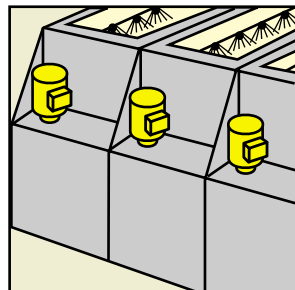

PCB WET PROCESSING

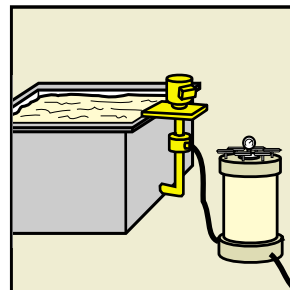

**OUT-OF-TANK PUMPING
and FILTRATION**

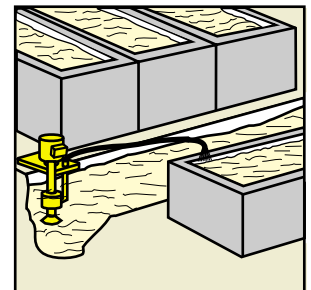

**SUMP DRAINING and
WASTE TREATMENT**

SERIES 'EO' Performance and dimensions

MODEL EO1

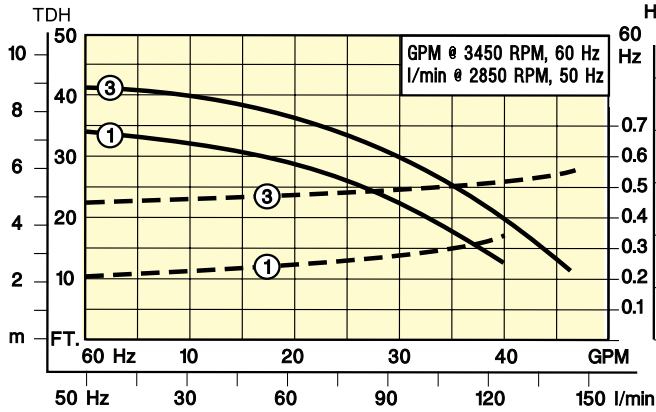

MODEL EO1¼

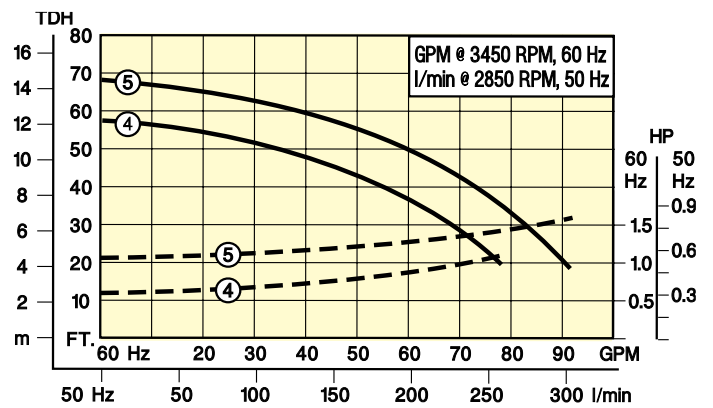

LEGEND:HP --- FLOW — HP

DIMENSIONS (In.)

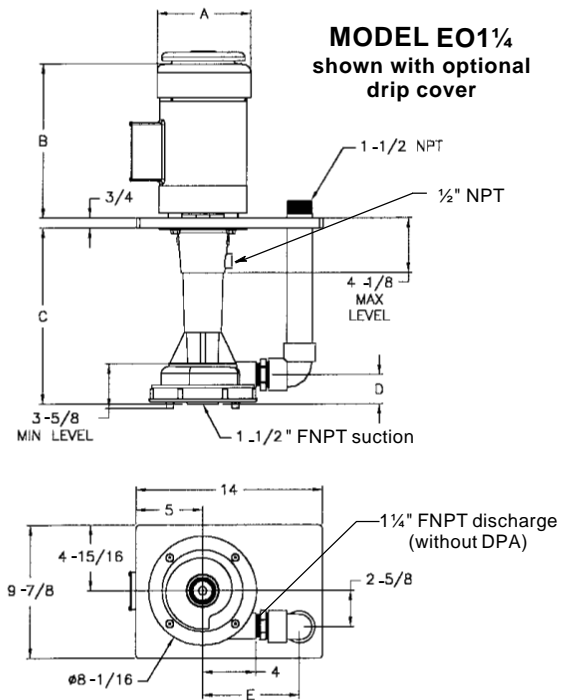
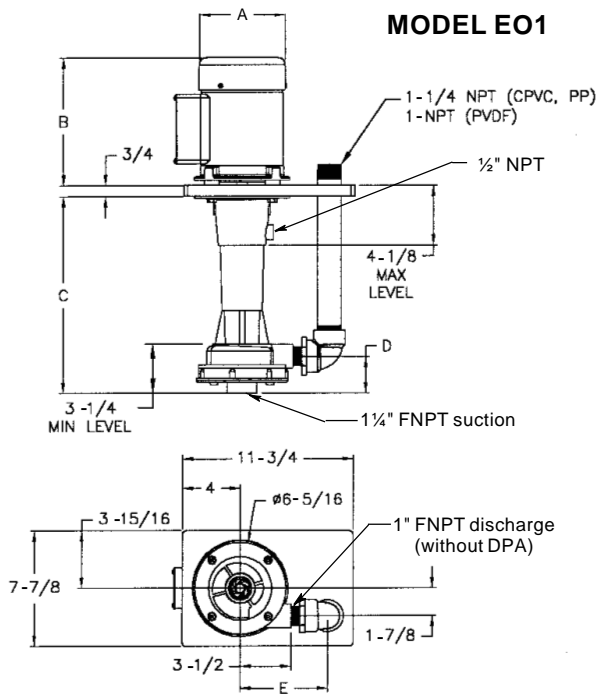

PUMP MODEL	MATERIAL	A	B	C	D	E
EO1	CPVC	—	—	13-3/16	2-5/16	6
	PP	—	—	13-3/16	2-5/16	6-3/8
	PVDF	—	—	13-3/16	2-5/16	5-3/8
	.33 HP	5-7/8	8-1/2	—	—	—
	.75 HP	7-1/8	9-5/8	—	—	—
EO1¼	CPVC	—	—	13-1/4	2-5/16	7-1/4
	PP	—	—	13-1/4	2-5/16	7
	PVDF	—	—	13-1/4	2-5/16	7
	1 HP	7-1/4	10-5/8	—	—	—
	1.5 HP	7-1/4	10-5/8	—	—	—

SERIES 'EO' Ordering information

TABLE I Select flow curve and material. Use Price Code No. to order.

FLOW CURVE NO.	MAX. FLOW ¹	POLYPROPYLENE / VITON		CPVC / VITON		PVDF / VITON	
		MODEL	PRICE CODE NO.	MODEL	PRICE CODE NO.	MODEL	PRICE CODE NO.
1	40	EO1PPV1-C.3	39-1121 A	EO1CV1-C.3	39-1221 A	EO1KV1-C.3	39-1321 A
3	47	EO1PPV3-C.75	39-1123 C	EO1CV3-C.75	39-1223 C	EO1KV3-C.75	39-1323 C
4	78	EO1¼PPV4-D1.0	39-2124 J	EO1¼CV4-D1.0	39-2224 J	EO1¼KV4-D1.0	39-2324 J
5	92	EO1¼PPV5-D1.5	39-2125 K	EO1¼CV5-D1.5	39-2225 K	EO1¼KV5-D1.5	39-2325 K

¹ Maximum flow (U.S. GPM) @ 60 Hz with 1.0 specific gravity liquid at ambient temperature.

TABLE II To select pump with EPDM elastomer or for use with elevated specific gravity at required GPM, TDH and material: Select performance point on curve, determine required HP by moving vertically from GPM to corresponding number dotted line. Read the required HP at right ordinate and multiply by S.G. This is the HP required. Construct Model and Price Code No. by adding series, size, material, elastomer, impeller and motor from charts below. Use Price Code No. to order.

SERIES		SIZE			MATERIAL			ELASTOMER		
MODEL	PRICE CODE NO.	MODEL	PRICE CODE NO.	DESCRIPTION	MODEL	PRICE CODE NO.	DESCRIPTION	MODEL	PRICE CODE NO.	DESCRIPTION
EO	39-	1 1¼	1	1¼ x 1	PP	1	Polypropylene	L	1	EPDM
			2	1½ x 1¼	C	2	CPVC	V	2	Viton
					K	3	PVDF			

IMPELLER / FLOW CURVE			TEFC MOTOR - 1φ ²			TEFC MOTOR - 3φ ³		
MODEL	PRICE CODE NO.	DESCRIPTION	MODEL	PRICE CODE NO.	HORSEPOWER	MODEL	PRICE CODE NO.	HORSEPOWER
1	1	2¾" for EO1	C.3	A	.33	D.3	F	.33
3	3	3" for EO1	C.75	C	.75	D.75	H	.75
4	4	3¾" for EO1¼	C1.0	D	1.0	D1.0	J	1.0
5	5	4" for EO1¼	C1.5	E	1.5	D1.5	K	1.5
						D2.0	L	2.0

² 1φ motors are:
115-208/230 @ 60 Hz, 3450 RPM
115-220/240 @ 50 Hz, 2850 RPM

³ 3φ motors are:
208-230/460 @ 60 Hz, 3450 RPM
190-380/415 @ 50 Hz, 2850 RPM

OPTIONAL EQUIPMENT

DESCRIPTION	ADD SUFFIX TO MODEL	ADD TO PRICE CODE NO.
Through hole in standard mounting plate	MPH	X
Titanium option - shaft and fasteners	T	T
Drip cover - installed (Not available on .33 HP models)	DC	Z

EO1 PUMP

DESCRIPTION	PRICE CODE NO.
DISCHARGE PIPE ASSEMBLY Polypropylene 1¼" CPVC 1¼" PVDF 1"	39-1000 PP 39-1000 C 39-1000 K
18" SUCTION EXTENSION Polypropylene 1½" CPVC 1¼" PVDF 1½"	39-1004 PP 39-1004 C 39-1004 K
SUCTION STRAINER Polyethylene / PP Polyethylene / CPVC ECTFE (Halar®) / PVDF	39-1002 PP 39-1002 C 39-1003 K

EO1¼ PUMP

DESCRIPTION	PRICE CODE NO.
DISCHARGE PIPE ASSEMBLY Polypropylene 1½" CPVC 1½" PVDF 1½"	39-2000 PP 39-2000 C 39-2000 K
18" SUCTION EXTENSION Polypropylene 1½" CPVC 1¼" PVDF 1½"	39-2004 PP 39-2004 C 39-2004 K
SUCTION STRAINER Polyethylene / PP Polyethylene / CPVC ECTFE (Halar®) / PVDF	39-2002 PP 39-2002 C 39-2003 K

Specifications subject to change without notice.